



**DRIP PANS**

*Top Mounted, Angled, Recessed, Cutout and Spacesaver*

JOB	
AREA	
ITEM NO.	
MODEL NO.	



5020



C21379A

MODELS
Top-Mounted
Angled
Recessed
Cutout
Spacesaver



C18635A

**KEY PRODUCT FEATURES AND BENEFITS**

- Keep your bar clean and dry with Perlick drainers
- Liquid automatically flows out of the drainer ensuring a clean and hygienic bar space
- Removable glass rack makes it quick and easy to clean

**Additional Features:**

- Drip pans equipped with a four-inch, 1/2" O.D. drain socket and a removable glass rack
- All-stainless steel construction
- 1/2" O.D. drain socket
- Removable glass rack
- Stainless steel and tarnish free brass finishes



**DRIP PANS**  
*Top Mounted, Angled, Recessed, Cutout and Spacesaver*

**TOP MOUNTED**

5000 SERIES MODEL NUMBERS	Stainless Steel	5015	5020	5025	5028	5030	5034	5036	5124	5130
	Tarnish-Free Brass	5015TF	5020TF	5025TF	5028TF	5030TF	N/A	N/A	N/A	N/A
OVERALL LENGTH (mm)		5-3/8" (137)	13-3/4" (349)	19" (483)	24" (610)	37" (940)	47-1/16" (1195)	59-7/8" (1521)	40-1/16" (1017)	48-5/8" (1235)
DRIP PAN LENGTH (mm)		4-3/8" (111)	12-3/4" (324)	18" (457)	23" (584)	36-1/8" (918)	46-3/16" (1173)	59" (1499)	39-3/16" (995)	47-3/4" (1213)
OVERALL WIDTH (mm)		5-3/8" (137)	4-7/8" (124)	4-7/8" (124)	4-7/8" (124)	4-7/8" (124)	4-15/16" (125)	4-15/16" (125)	7-7/16" (189)	7-7/16" (189)
DRIP PAN WIDTH (mm)		4-3/8" (111)	3-7/8" (98)	3-7/8" (98)	3-7/8" (98)	3-7/8" (98)	4-1/16" (103)	4-1/16" (103)	6-9/16" (166)	6-9/16" (166)
DRIP PAN and GLASS RACK	Stainless steel or tarnish-free brass						Stainless steel			
PLUMBING	Equipped with 9/16" I.D. waste drain and universal drain tubes. Use with 1/2" N.P.T. pipe fittings or 1390D 1/2" I.D. flexible drain tube.									

18000 SERIES MODEL NUMBERS	Stainless Steel	C18635A	C18640A	C18645A	C18650A	C18655	C18660	C18663	C18665	
	Tarnish-Free Brass	C18635ATF	C18640ATF	C18645ATF	C18650ATF	C18655TF	N/A	N/A	N/A	
OVERALL LENGTH (mm)		8-3/4" (222)	14-3/16" (360)	20-3/4" (527)	26-3/4" (679)	33" (838)	46-9/16" (1182)	52-7/16" (1332)	59-3/4" (1517)	
DRIP PAN LENGTH (mm)		7-7/16" (179)	12-7/8" (327)	19-7/16" (494)	25-1/2" (648)	31-3/4" (787)	45-5/16" (1151)	51-3/16" (1300)	58-1/2" (1486)	
OVERALL WIDTH (mm)		7-3/4" (197)	7-3/4" (197)	7-3/4" (197)	7-3/4" (197)	7-3/4" (197)	7-3/4" (197)	7-3/4" (197)	7-3/4" (197)	
DRIP PAN WIDTH (mm)		6-1/2" (165)	6-1/2" (165)	6-1/2" (165)	6-1/2" (165)	6-1/2" (165)	6-1/2" (165)	6-1/2" (165)	6-1/2" (165)	
DRIP PAN and GLASS RACK	Stainless steel or tarnish-free brass						Stainless steel			
PLUMBING	Equipped with 1/2" I.D. brass drain tube with 1/2" NPSM thread and machined end to accept 1/2" I.D. flexible drain tube.									

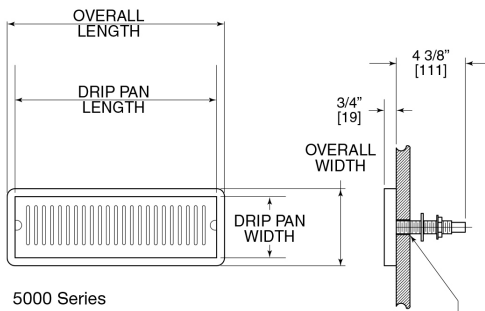

5000 Series

TO INSTALL DRIP PAN, DRILL 15/16" [24] DIA. HOLE THRU COUNTER TOP.

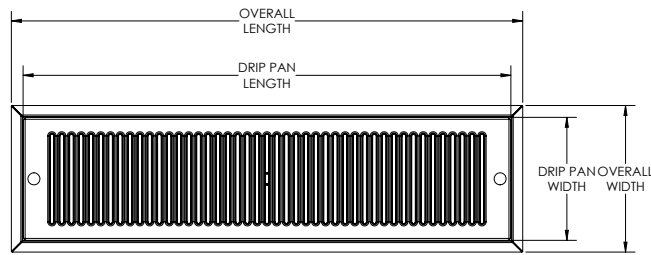

18000 SERIES

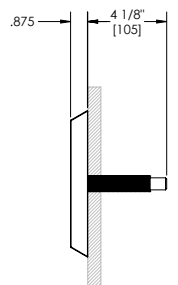



MODEL NUMBERS	Stainless Steel	57120
	Tarnish-Free Brass	57120TF
OVERALL LENGTH (mm)	20-1/4" (511)	
OVERALL WIDTH (mm)	9" (229)	
DRIP PAN and GLASS RACK	Stainless steel or tarnish-free brass. Plastic grid-style glass rack glass rack.	
PLUMBING	Equipped with 1/2" I.D. brass drain tube with 1/2" NPSM thread and machined end to accept 1/2" I.D. flexible drain tube.	

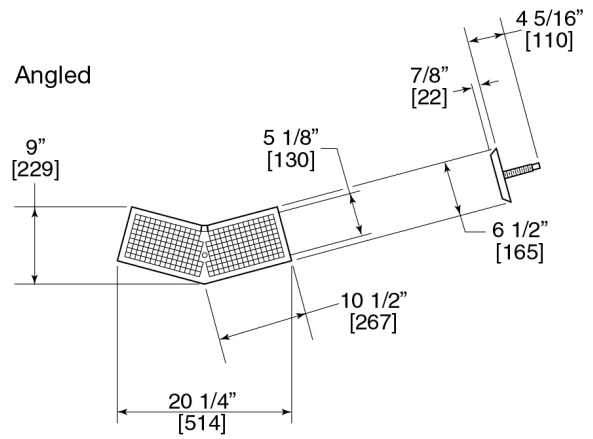

**RECESSED**

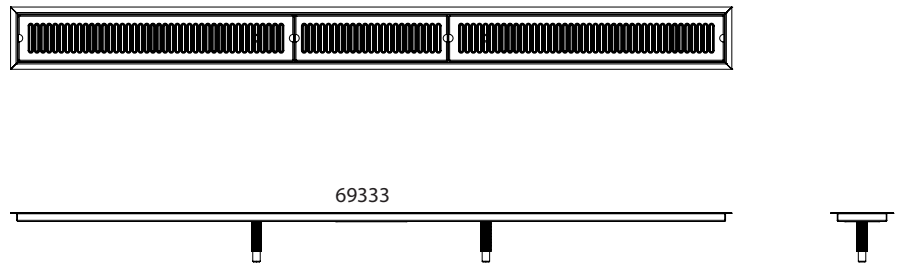
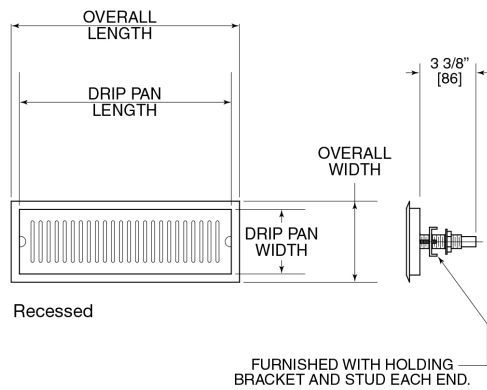



**DRIP PANS**  
*Top Mounted, Angled, Recessed, Cutout and Spacesaver*

**CUTOUT**

MODEL NUMBERS	Stainless Steel	6230355	
	Tarnish-Free Brass		62304
DIMENSIONS "A" (mm)		14-1/16" (357)	20-3/4" (527)
DIMENSIONS "B" (mm)		12-7/8" (327)	19-7/16" (494)
DIMENSIONS "C" (mm)		7-5/8" (194)	5-1/8" (130)
DRIP PAN and GLASS RACK	Brass or stainless steel. Stainless steel glass rack.		
PLUMBING	Chrome plated brass drain and 3/8" elbow hose coupling.		

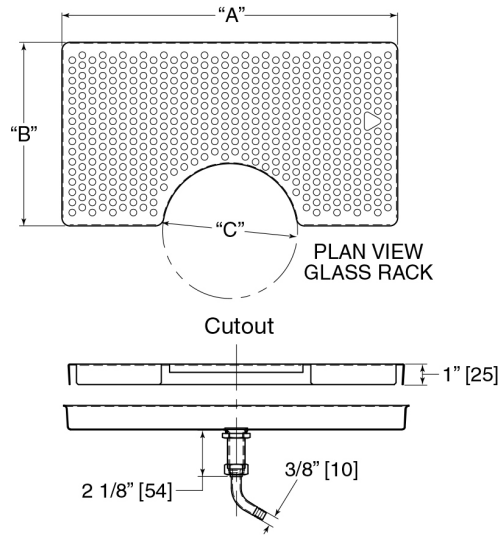

**SPACESAVER DRIP PANS**

MODEL NUMBERS	Stainless Steel	3713-1	3721-1
LENGTH (mm)		12-7/8" (327)	21-1/8" (537)
DEPTH (mm)		8-7/8" (225)	8-7/8" (225)
HEIGHT (mm)		14-3/4" (325)	14-3/4" (375)
DRIP PAN and GLASS RACK	Stainless steel.		
PLUMBING	Equipped with 1/2" I.D. brass drain tube with 1/2" NPSM thread and machined end to accept 1/2" I.D. flexible drain tube.		

