

INSTALLATION AND OPERATION INSTRUCTIONS SINGLE KEG DISPENSER

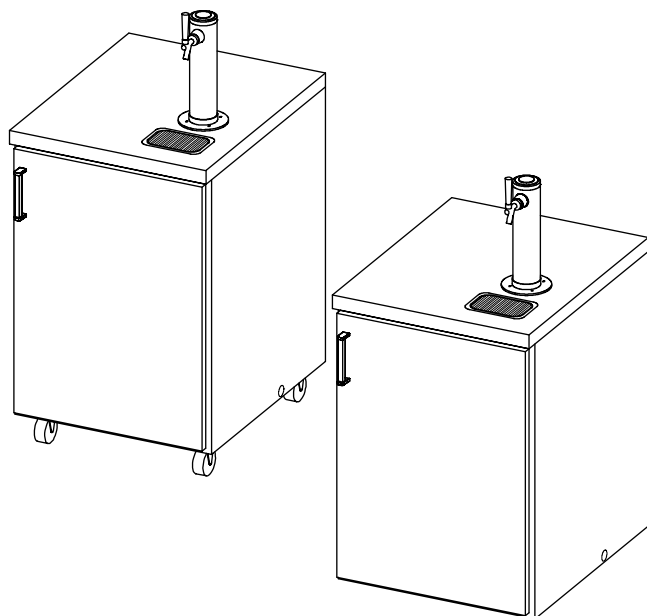

IMPORTANT INFORMATION

A Warranty card is enclosed that must be filled out and mailed to the Perlick Corporation in order to register the warranty. If the card is not returned to Perlick, the warranty period will begin from the date the equipment is shipped from the factory.

This manual has been prepared to assist you in the installation of your Single Keg Dispenser and to acquaint you with its operation and maintenance.

We dedicate considerable time to ensure that our products provide the highest level of customer satisfaction. If service is required, your dealer can provide you with a list of qualified service agents. For your own protection, never return merchandise for credit without our approval.

We thank you for selecting a Perlick product and assure you of our continuing interest in your satisfaction.

WARNING: When lifting, the full weight of the cabinet must be supported. Lift from the cabinet base and not from the top. Improper lifting can result in severe damage to the cabinet.

MODEL NOS.

DS1KP

DP1KP



ANSI / NSF #7



Table of Contents

PREPARING THE CABINET FOR USE

Specifications.....	2
List of Included Parts.....	3
Tools Required.....	3
Plumbing.....	3
Electrical.....	3
Uncrating.....	3
Installing Casters.....	3
Placing the Cabinet.....	3
Leveling the Cabinet.....	3
Installing Faucet and Standard.....	3

TAPPING

Connecting the Keg Coupler.....	4
Tapping the Keg.....	4
Connecting the Regulator.....	4
Adjusting Gas Flow.....	4
CO ₂ Leak Test.....	5
Replacing a CO ₂ Gas Cylinder.....	5
Handling CO ₂ Gas.....	5

TEMPERATURE

Beer Temperature.....	6
Refrigeration and Temperature Control.....	6
Adjusting the Temperature.....	6

CLEANING

Cleaning the Beer System.....	7
Cleaning the Cabinet.....	7
Cleaning the Condenser.....	7
Condenser.....	7

GENERAL INFORMATION

How to Pour a Perfect Glass of Beer.....	8
Troubleshooting.....	9
REPLACEMENT PARTS.....	10-11
Wiring Diagram.....	12



8300 West Good Hope Road • Milwaukee, WI 53223 • Phone 414-353-7060 • Fax 414-353-7069
Toll Free 800-558-5592 • E-Mail: Perlick@Perlick.com • www.Perlick.com

Installation and Operating Instructions

Sizes and Specifications, Single Keg Dispensers

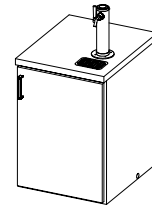
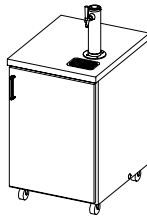

MODEL NOS.	DP1KP	DS1KP
CABINET STYLE	Portable	Underbar
HALF BARREL CAPACITY	1 Keg	1 Keg
CONDENSING UNIT H.P.	1/6 h.p	1/6 h.p
AMPS	3.2	3.2
SHIP WT lbs. (kg)	205 (93)	200 (91)
INTERIOR	Door Sill: Reinforced 14 gauge stainless steel sill. Door Pan: High strength polystyrene. Floor Pan: Stainless steel. Walls & Ceiling: Galvanized steel.	
EXTERIOR	Stainless steel top with recessed drainer with removable glass rack. Door, front, back and ends, black powder coated steel. Base is black painted galvanized steel. Portable Model: Includes four, 3 ³ / ₄ " locking casters.	
REFRIGERATION	R-134a capillary tube-type. Aluminum fin and copper tube evaporator coil. Forced air into dispensing head. Adjustable temperature control. Self-defrosting.	
VENTILATION	Two inches of clearance is required behind cabinet for proper air flow.	
ELECTRICAL	115 Volt, 60 Hz., 1 Phase AC. Furnished with three prong, six foot rubber cord. Contact Perlick-Milwaukee for other voltages/frequency requirements.	
PLUMBING	Underbar Model: Floor drain 3/4" female taper pipe exits out right bottom or right end. Portable Model: None required. Liquid waste bottle provided.	
OPTIONAL ACCESSORIES	<ul style="list-style-type: none"> • Door Lock • CO₂ gas cylinder (#5) • Leg Set • Keg Coupler • Primary Regulator • Faucet Lock 	

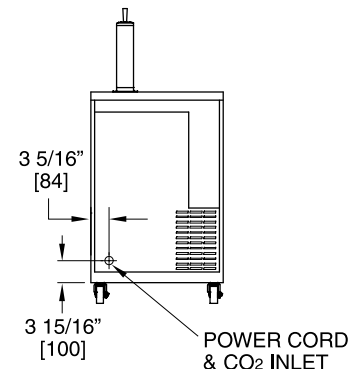
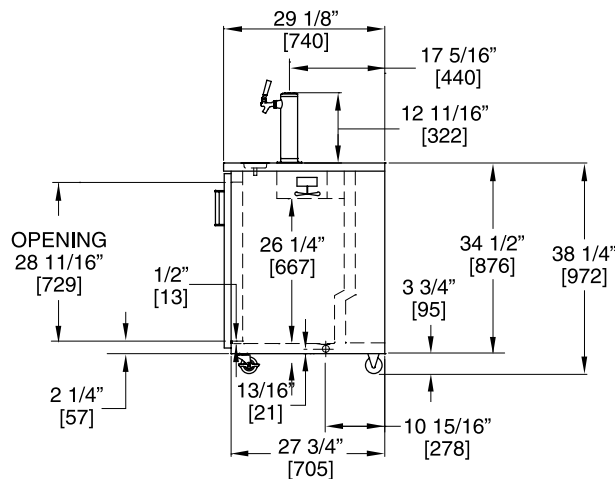
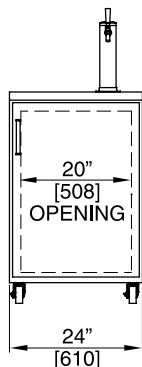
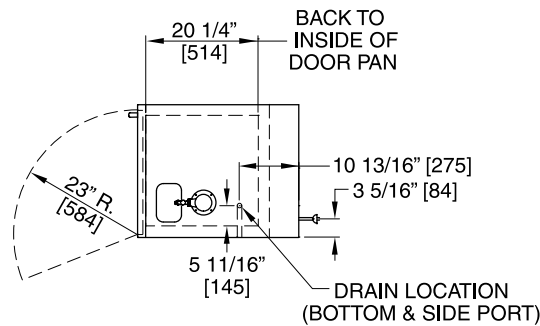

Perlick is committed to continuous improvement. Therefore, we reserve the right to change specifications without prior notice.

Preparing the Cabinet for Use – Single Keg Dispensers

Parts List

- Rigid Casters.*
- Swivel Casters w/Lock.
- A/C Faucet Standard.
- Faucet Head Assembly.
- Spanner Wrench for Faucet.
- Black Connector Hose $\frac{3}{16}$ " x 3'.
- $\frac{5}{16}$ " Air Hose.
- Bag of Miscellaneous Parts.
- Plastic Waste Bottle.*

* Portable Model Only.

Tools Required

- #2 Phillips Screwdriver.
- Spanner Wrench (included).
- 10" Crescent Wrench.
- $\frac{9}{16}$ " Allen Wrench.
- $\frac{3}{8}$ " Nut driver.

Plumbing

Portable Model

No plumbing connections are required. Condensate from the cooling coil is automatically evaporated. Drain pan waste is accumulated in the plastic bottle installed inside the cabinet.

Underbar Model

Features a floor drain with a $\frac{3}{4}$ " female pipe thread connection for disposal of both condensate and drip pan waste. Remove bottom or side drain plug with Allen wrench and attach $\frac{3}{4}$ " male pipe to external drain.

Electrical

The cabinet must be connected to a separately fused power source (see electrical specification plate) and grounded in accordance with National and Local Electrical Codes. Caution: Do not attempt to operate the equipment on any other power source than that listed on the Electrical Specification plate.

Uncrating and Inspection

Remove all crating material before operating. Carefully inspect cabinet for hidden damage. If damage is discovered, file your claim immediately with the transportation company. Perlick is not responsible for damage in transit.

Installing Casters (Portable Models Only)

Attach four casters to the cabinet bottom; rigid casters at the rear and swivel casters on the front. Use the supplied $\frac{1}{4}$ "- 20 x $\frac{3}{4}$ " hex head self-tapping machine screws.

Placing the Cabinet

Push the cabinet into place using rollers when necessary. Important: Proper air flow around the condensing unit is necessary for efficient operation. Never obstruct the air flow in and out of the condensing unit.

Leveling the Cabinet

When the cabinet is in place, check installation with carpenter's level. When perfectly level, accumulated water will drain out. A slight pitch to the drain side will not harm the cabinet. Water may accumulate if cabinet is pitched to the opposite side.

Installing the Faucet and Dispensing Head

Before you begin: Wash dispensing head and faucet. Flush beer, dispensing head and faucet lines with fresh water.

- Apply RTV around the base of the dispensing head to seal it to the top. Align the dispensing head over the five holes on the cabinet top and use the five stainless steel #10-32 x $\frac{1}{4}$ " Phillips pan head stainless steel machine screws to secure standard to cabinet top. Wipe off excess RTV to complete the seal.
- Attach faucet to standard using spanner wrench to tighten coupling. Attach faucet handle to faucet.
- Insert flexible plastic air hose six to seven inches into bottom of faucet standard. Secure hose with tie wrap (supplied).

Installation and Tapping – Single Keg Dispensers

Connecting the Keg Coupler (when Supplied by Perlick)

- Place one brown leather washer into black beer line connector hose on hex nut side. Screw connector to stainless steel beverage line on faucet standard. Tighten with a wrench, but do not over tighten.
- Make sure lever handle on the keg coupler is in the **UP** (untapped) position. Place one brown leather washer into wing nut end of black beer line connector hose and thread onto top of keg coupler. Hand tighten.
- Place clamp on one end of red air line. Push end over air valve located inside cabinet. Tighten clamp with screwdriver. Turn shut-off valve to **OFF** (horizontal) position.
- Place clamp on the other end of red air line and push over tailpiece on coupler. Tighten clamp with screwdriver.

CAUTION: Do not use keg coupler as a handle to lift keg.

Tapping a Single Valve Keg (Sankey):



Single Valve Keg Coupler

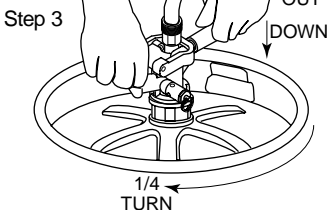
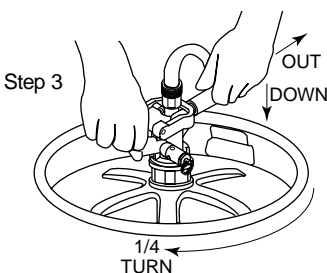
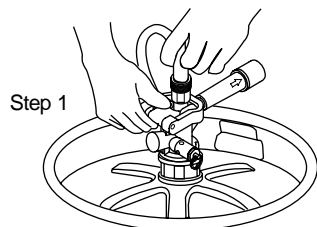

- Be sure beer faucet is in closed position.
- Align keg lugs with lug openings on bottom of coupler.
- Turn clockwise $\frac{1}{4}$ turn. Pull handle out and down. Keg is now tapped.
- Open shut-off valve on air distributor located inside of the cabinet.

Important: Be sure to close this valve when untapping keg.

Connecting the Regulator to the CO₂ Cylinder

- Remove blue plug from regulator fitting. (Note: Do not remove the carbonic washer).
- Screw regulator onto gas cylinder valve. Tighten with wrench until vertically straight. Be sure that shut-off valve (**black lever**) on regulator is in the **OFF (horizontal)** position.
- Place a screw clamp over end of red air line and push onto regulator tailpiece. Tighten clamp with a screwdriver.

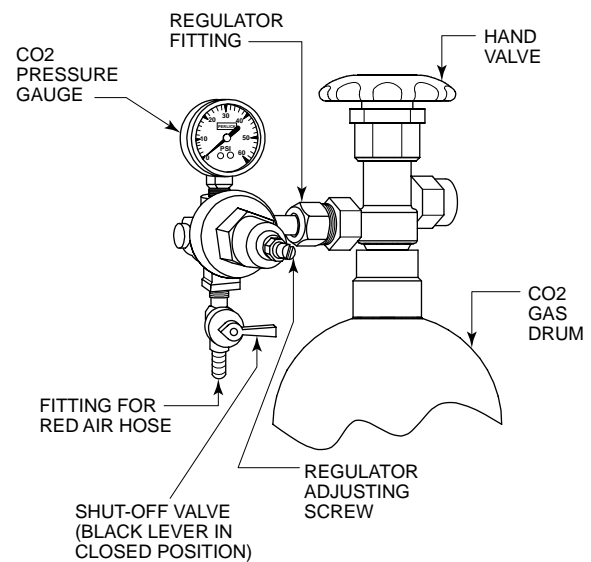

Adjusting the CO₂ Gas Flow

- Turn regulator adjusting screw counterclockwise until it turns freely.
- Turn hand valve counterclockwise on CO₂ cylinder to the fully open position.
- Turn regulator adjusting screw clockwise until desired pressure is reached (approximately 12-15 lbs.). Tighten stop nut on adjusting screw.
- Open shut-off valve on bottom of regulator.



Installation and Tapping – Single Keg Dispensers

CO₂ Leak Test

Dilute a small amount of liquid dishwashing soap and rub the soapy mixture around each connection. If bubbles appear, tighten connection.

Replacing CO₂ Gas Cylinder

- Turn CO₂ hand valve clockwise until seated and close shut-off valve on regulator.
- Unscrew regulator from cylinder fitting.
- Replace carbonic washer (Part No. 157F2P), if needed and reattach regulator to filled cylinder.
- Turn CO₂ hand valve counterclockwise until fully open. Turn regulator shut-off valve to open position.
- Adjust CO₂ gas flow as required, turning clockwise for higher pressure.

Proper CO₂ Handling

ALWAYS...

- Connect a regulator (reducing valve) to CO₂ cylinder.
- Secure cylinder in upright position whether in storage or in use.
- Keep cylinder away from heat. Rupture disc vents at 122° F. maximum.
- Ventilate room after high pressure gas leakage.
- Check the last DOT test date on cylinder neck before filling. If more than five years old, the cylinder must be retested to DOT specifications.
- Be sure CO₂ cylinder outlet fitting is free of dust

or dirt before attaching regulator.

- Store CO₂ cylinder and regulator assembly upright.
- Allow only properly trained and experienced personnel to handle high pressure gas.

NEVER...

- Connect cylinder directly to a keg without a regulator (reducing valve).
- Drop or throw regulator or CO₂ cylinder.
- Transport CO₂ cylinder in a closed vehicle.
- Apply oil to a regulator.
- Shut off CO₂ cylinder when not in use. You will not save gas by doing so!
- Allow untrained, inexperienced personnel to handle high pressure gas.

Failure to heed this warning could result in personal injury or death.

WARNING/SAFETY INSTRUCTIONS

Beverage systems pressurized with carbon dioxide or nitrogen must be equipped with two safety relief valves; one at the cylinder regulator and the other in the gas line upstream on the product tanks.



Draft Beer Information – Single Keg Dispensers

Temperature

One of the most common causes of dispensing problems is improper temperature. Draft beer should be stored at a temperature between 32° and 38°. At warmer temperatures, beer will foam.

At temperatures lower than 30° F., beer will freeze. When beer freezes, the alcohol in the beer may separate and cause the beer to be cloudy with an “off” taste.

HOW TEMPERATURE AFFECTS DRAFT BEER

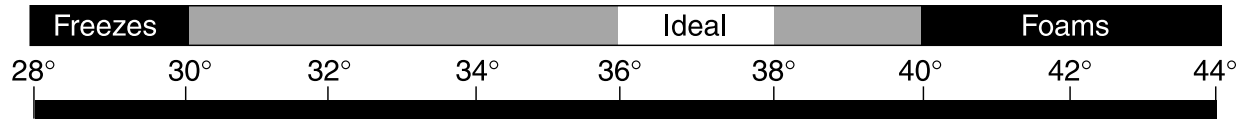

Draft beer is not pasteurized and must be kept cool at all times.

Refrigeration and Temperature Control

The Partymaster Dispenser is equipped with a heavy-duty refrigeration system designed to automatically maintain a storage temperature of 36-41 degrees F. The control is factory set at 38 degrees F.

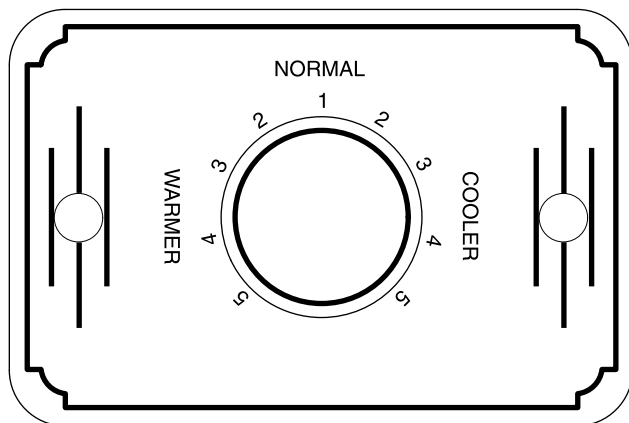

Adjusting the temperature

The temperature control is inside the cabinet on the right-hand side of the evaporator fan panel assembly. You will need a screwdriver to turn the adjusting screw. Make small adjustments until the desired temperature is achieved.

- **Colder Temperatures:**
Turn the adjusting screw clockwise (to the right).
- **Warmer Temperatures:**
Turn the adjusting screw counterclockwise (to the left).

In normal operation the condensing unit will run approximately 16 hours per day. The condenser fan motor turns off and on with the condensing unit. The evaporator fan motor runs continuously. The fan motors are lifetime lubricated and will require no oiling.

NOTE:

Cabinet Temperatures lower than 34° will not allow for proper defrosting of the evaporator coil. If defrosting is necessary, turn the control knob to the OFF position until coil is defrosted.



Perlick is committed to continuous improvement. Therefore, we reserve the right to change specifications without prior notice.

Cleaning the Beer System – Single Keg Dispensers

The entire beer system, to include the faucet, flexible beer line and tapping devices must be cleaned at regular intervals. We recommend flushing the entire system with fresh water immediately after a keg has been emptied. Once each month the system should be cleaned chemically.

It is recommended that you purchase Perlick's Pump Type Sterilizer, as shown below. It is equipped with an adapter that attaches directly to the faucet shank in lieu of the faucet. It is also available with a slip coupling for those who choose to clean their faucets in place.

Part Nos.	Description
887P	½ Gallon sterilizer w/faucet coupling.
887PSC	½ Gallon sterilizer w/slip coupling.
848A33	33 oz. liquid alkaline cleaner.



No. 887P

Cleaning the draft beer system will help to eliminate the build-up of the following materials:

- **Bacteria:**

Beer is an excellent food for bacteria (none of which is harmful). Proper conditions may begin the growth of bacteria in draft beer and on the beer faucet. By regular cleaning, we prevent this bacterial buildup and maintain the quality of the draft beer. Greenish or yellowish colored material on the faucet may indicate bacterial growth.

- **Yeast:**

All domestic draft beers contain a small amount of yeast which remains in the beer from the fermentation process. When the temperature of draft beer exceeds 50° a process of secondary fermentation may take place. The beer faucet may exhibit a white colored substance (yeast build up) if not cleaned on a regular basis.

- **Beer Stone:**

All beer contains calcium which is present from the grains used in the brewing process. It is an important natural material in draft systems in that as it oxidizes it coats the internal parts of the beer lines and equipment. This thin coat of beer stone helps prevent the beer from picking up strong metallic or plastic flavors as it flows through the system. The beer stone will continue to build if the system is not cleaned properly or regularly and can cause drawing problems if it begins to flake off. Beer stone is present if one can see a brownish color on the faucet or inner wall of the beer line, or tobacco-like flakes in the beer.

Cleaning the Cabinet

Use a mild detergent and water to clean the inside and outside of the cabinet. Dry thoroughly. Never use a scouring pad or abrasive cleanser.

NOTE: An industrial strength, commercial cleaner can be used to clean the outside of painted cabinets.

Cleaning the Condenser

Use a long handled, stiff brush to clean the dirt from the front surface of the condenser. Keeping the condenser free from dust and dirt will ensure efficient operation.

CAUTION: Do not bend the fins while brushing the front of the condenser.

Condenser

The condenser (located behind the back cover) should be inspected every 30 days and cleaned, if necessary. Failure to keep the condenser clean will cause a loss in condenser unit efficiency.

Pouring a Perfect Glass of Beer – Single Keg Dispensers

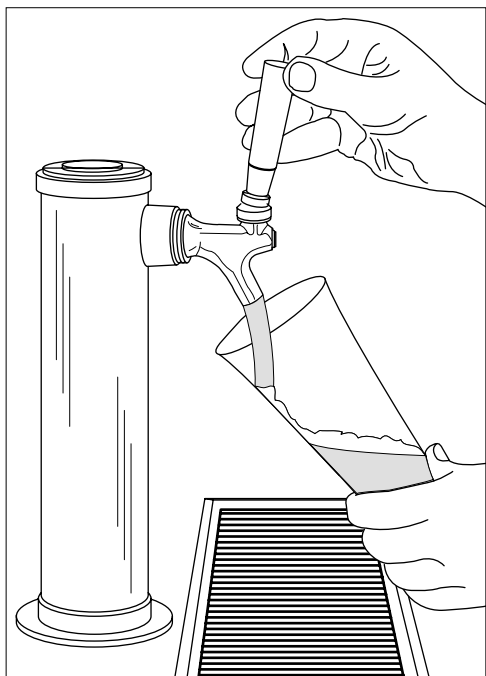

STEP 1

Start with a clean glass. Place the glass at a 45° angle, one inch below faucet. Do not let the glass touch the faucet. Open the faucet all the way.

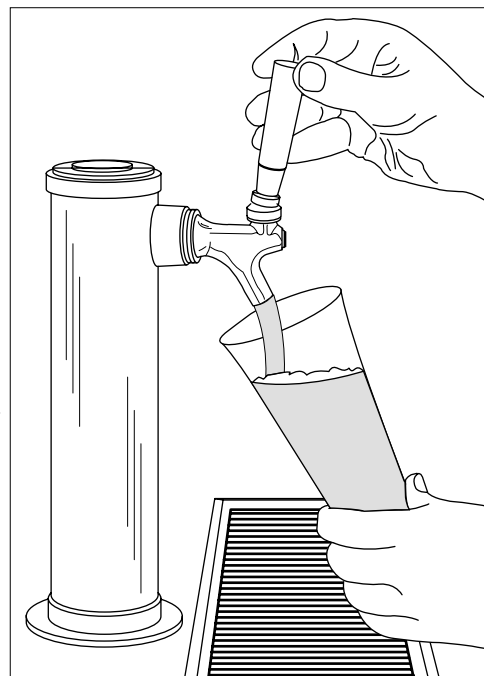

STEP 2

After the glass has reached half full, gradually bring the glass to the upright position

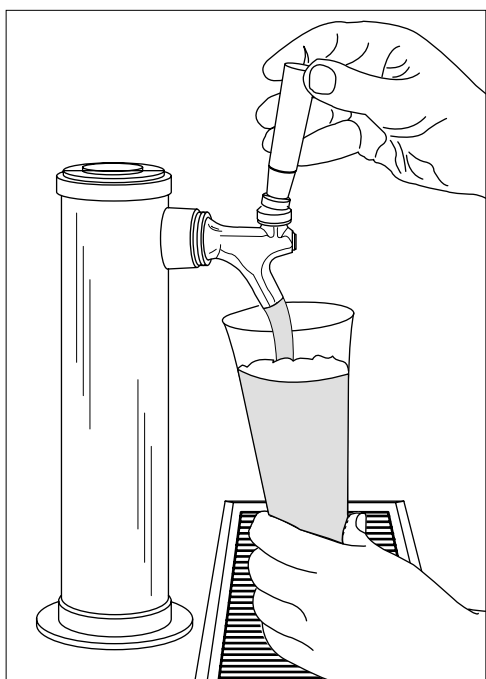

STEP 3

Let the remaining beer run straight down the middle of the glass. This ensures proper release of CO₂ by producing a 3/4" to 1" foam head.



STEP 4

Close the faucet quickly and completely.

Trouble Shooting – Single Keg Dispensers

Beer Service Problems

■ Wild Beer:

Dispensed beer has either too much foam or is all foam.

CAUSES:

- Beer has been dispensed improperly.

Solution: See pouring instructions on page 8.

- Regulator pressure is set too high.
- Warm keg temperature.

Solution: Keg must be colder than 40°. Target temperature is between 36° and 38° F.

- Cabinet door is opened and closed frequently and temperature is warmer than 38° F.

Solution: Adjust temperature to between 36° and 38° F.

- Kinks, dents or obstructions in the line.
- Using oddly shaped glasses. Frosted, waxed or styrofoam containers may cause foaming.
- Dispenser has been turned off for a long period of time.
- Faucet is bad, dirty or in a worn condition.
- Regulator malfunction.

■ Flat Beer:

Foamy head disappears quickly; beer lacks brewery fresh flavor.

CAUSES:

- Dirty glassware.
- CO₂ pressure is too low, due to leak or pressure setting.
- CO₂ is turned off at night.
- Cooler is too cold.
- CO₂ leak or defective (sticking) check valve.
- Sluggish CO₂ regulator.

■ Cloudy Beer:

Beer in glass appears hazy, not clear.

CAUSES:

- Dirty glass.
- Dirty faucet or beer line.
- Frozen or nearly frozen beer.
- Old beer.
- Beer that has not been refrigerated for a long period of time.

Beer and CO₂ Facts

Keg Size	No. of Gallons	No. of Oz.	No. of Cases	No. of 12Oz. Servings	Full Keg Weight
Quarter	7¾	992	3.445	105	87 lbs.
Half	15½	1,984	6.889	210	161 lbs.

- Beer foam is 25% liquid beer and 75% CO₂ gas. Don't waste it!
- Most people prefer beer stored at 38° F.
- Beer lines and faucets require regular cleaning (see cleaning instructions on page 7).
- A fully-charged 4.2 lb. CO₂ cylinder will dispense approximately 5½ to 6½ half barrels.
- CO₂ gas gives beer its sparkling effervescence. It also gives beer its creamy head of foam.

Replacement Parts – Single Keg Dispensers

MODEL NOS. Serial Numbers above 500,000		DP1KP	DS1KP
Item	Description	Part #'s	
1	Compressor for R134a	C22650	C22650
2	Condenser fan motor	C15240A	C15240A
3	Condenser fan motor bracket	61289-1	61289-1
4	Condenser fan blade	C6914	C6914
5	Condenser fan pan	62209-1	62209-1
6	Rear panel	62133-1	62133-1
7	Back panel partition	62131-1	62131-1
8	Condenser assembly	C18634A	C18634A
9	Condenser panel	62132-1	62132-1
10	Evaporator fan guard	C25400A1	25400A1
11	Evaporator fan blade - 5½"	C14649	C14649
12	Evaporator fan motor	C15239A	15239A
13	Evaporator assembly - complete	62212A	62212A
14	Top assembly	62221	62221
15	Glass rack	C17965-1	C17965-1
16	Waste bottle holder	C24391-1*	C24391-1*
17	½" Plastic winged washer	C31990*	C31990*
18	Drain elbow (underbar only)	57752-1	57752-1
19	Plastic waste bottle	C24392*	C24392*
20	Temperature control parts kit	57360	57360
21	Air shut off line assembly	C4168A	C4168A
22	Air-duct hose assembly kit	57852	57852
23	Air duct	61158-1	61158-1
24	Right hinged door assembly	64357SRBL	64357SRBL
	Left hinged door assembly	64357SLBL	64357SLBL
25	Door hinge kit, right	63407R	63407R
	Door hinge kit, left	63407L	63407L
26	Magnetic door gasket	62085-1	62085-1
27	Door sill	60944-1	60944-1
28	3" swivel caster	C22331	C2233-1
29	3" rigid caster	C22332	C22332
30	Single faucet draft arm	63251	63251
Parts Not Shown on Drawing			
	Wiring harness	61346-1	61346-1
	Door lock with keys	57851	57851
	Drain line hose kit (underbar only)	57854	57854

*For portable units only.

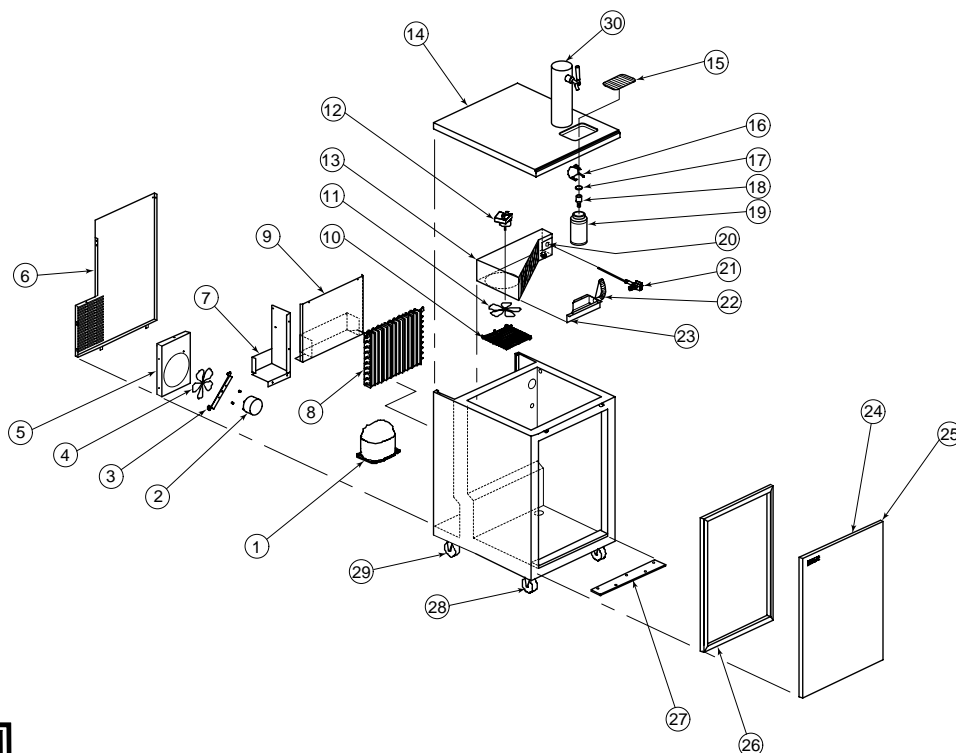

Perlick is committed to continuous improvement. Therefore, we reserve the right to change specifications without prior notice.

Replacement Parts – Single Keg Dispensers

For Single Valve Keg Coupler (Series D)

Item No.	Part No.	Description
1	26000D	Single valve keg coupler
2	C14316	"O" ring
3	31080-2P	Ball check
4	31089-2P	"O" ring (3 per assembly)
5	31088-2P	Bottom seal washer
6	31087-2P	Probe washer domestic
7	157R2P	Coupling Gasket
8	23682-2P	Check valve

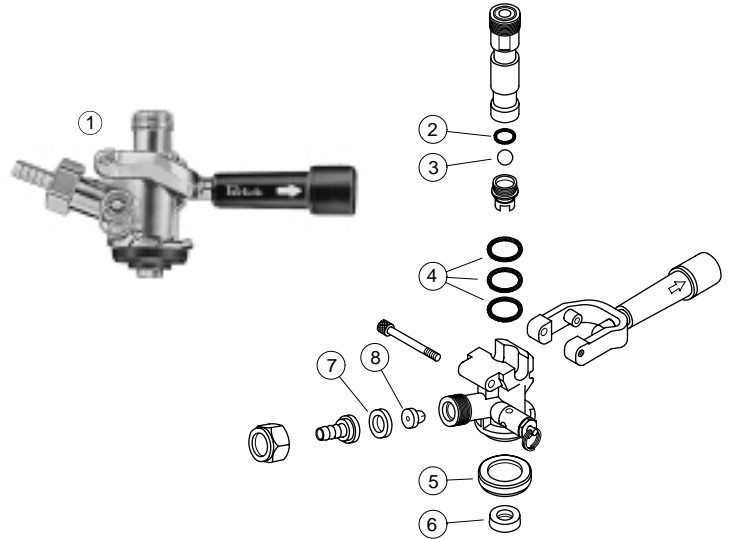

Miscellaneous

Part No.	Description
157L2P	Beer line connector gasket
57F2P	CO ₂ tank washer
1392R	Red air hose
529	Beer hose
2928D	Twin gauge CO ₂ regulator

Wiring Diagram – Single Keg Dispensers

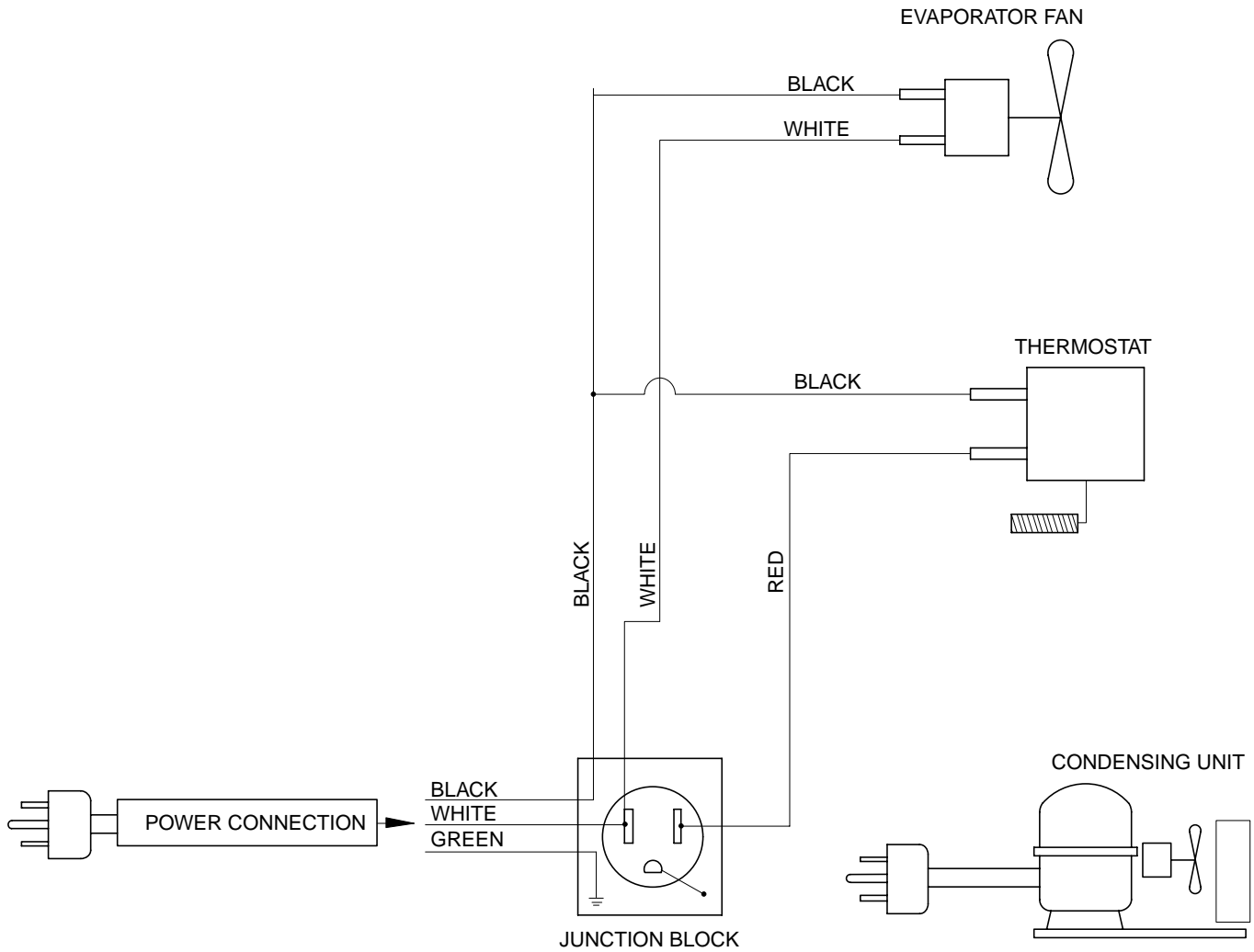

8300 West Good Hope Road • Milwaukee, WI 53223 • Phone 414-353-7060 • Fax 414-353-7069
Toll Free 800-558-5592 • E-Mail: Perlick@Perlick.com • www.Perlick.com

Perlick is committed to continuous improvement. Therefore, we reserve the right to change specifications without prior notice. Form No. Z2022A Rev. 07.22.04