

INSTALLATION AND OPERATION INSTRUCTIONS

DIRECT DRAW DISPENSER - REMOTE MODELS

MODEL NOS.

DR Series

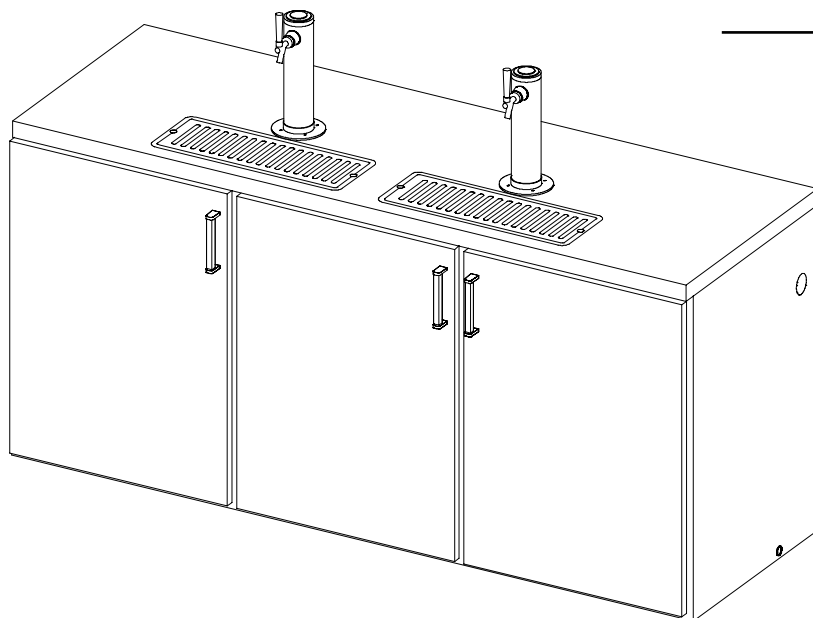

IMPORTANT INFORMATION

Complete the enclosed warranty card and mail to the Perlick Corporation to register the warranty. If the card is not returned, the warranty period will begin from the date the equipment is shipped from the factory.

This manual has been prepared to assist you in the installation of your Direct Draw Dispenser and to acquaint you with its operation and maintenance.

We dedicate considerable time to ensure that our products provide the highest level of customer satisfaction. If service is required, your dealer can provide you with a list of qualified service agents. For your own protection, never return merchandise for credit without our approval.

We thank you for selecting a Perlick product and assure you of our continuing interest in your satisfaction.

WARNING: When lifting, the full weight of the cabinet must be supported. Lift from the cabinet base and not from the top. Improper lifting can result in severe damage to the cabinet.

Table of Contents

PREPARING THE CABINET FOR USE	
Specifications.....	2
List of Included Parts.....	3
Tools Required.....	3
Plumbing.....	3
Electrical.....	3
Installing Casters or Legs.....	3
Installing Faucet and Standard.....	3
TAPPING	
Connecting the Keg Coupler.....	4
Tapping the Keg.....	4
Connecting the Regulator.....	5
Adjusting Gas Flow.....	5
CO ₂ Leak Test.....	5
Replacing a CO ₂ Gas Cylinder.....	5
Handling CO ₂ Gas.....	5
TEMPERATURE	
Beer Temperature.....	6
CLEANING	
Cleaning the Beer Lines.....	7
Cleaning the Cabinet.....	7
GENERAL INFORMATION	
How to Pour a Perfect Glass of Beer.....	8
Troubleshooting.....	9
Beer Facts.....	9
REPLACEMENT PARTS10-11	
Wiring Diagram.....	12



Installation and Operating Instructions

Sizes and Specifications, Direct Draw Dispensers - Remote

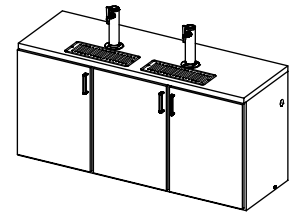
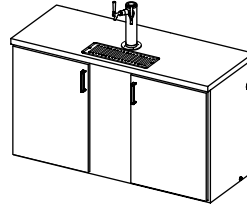
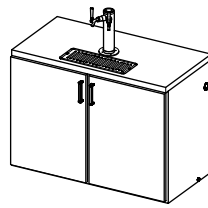

MODEL NUMBERS

PAINTED	DR2KP	DR3KP	DR4KP
STAINLESS STEEL	DR2KS	DR3KS	DR4KS

SPECIFICATIONS

KEG CAPACITY	2 Keg	3 Keg	4 Keg
NUMBER OF DOORS	2	2	3
LENGTH Ins. (mm)	48" (1219)	60" (1524)	72" (1829)
NO. OF DISPENSING HEADS	1	1	2
NO. FAUCETS	2	2	2
EVAPORATOR BTU/HR	1800	2200	2200
RUNNING LOAD - AMPS	.82	.82	.82
LIQUID INLET LINE SIZE	1/2" O.D.	1/2" O.D.	1/2" O.D.
SUCTION LINE SIZE	3/8" O.D.	3/8" O.D.	3/8" O.D.
SHIP WT lbs. (kg)	250 (114)	310 (141)	350 (159)
INTERIOR	Fourteen gauge stainless steel sills are reinforced with a 12 gauge angle bracket that extends from one end of the insulated base to the other. The floor pan is 20 gauge, type 304 stainless steel. The walls and ceiling are 20 gauge galvanized steel.		
EXTERIOR	All Models: The top is 20 gauge stainless steel. The back is 20 gauge galvanized steel. Bottom is 20 gauge stainless steel. Black Models: Doors, front and sides are 20 gauge black powder coated steel. Stainless Models: Doors, front and sides are 20 gauge stainless steel.		
ELECTRICAL	115 Volt, 60 Hz., 1 Phase AC. Contact Perlick for other voltage/frequency requirements.		
PLUMBING	Floor drain 3/4" female taper pipe exits out right bottom or right end.		
REFRIGERATION	Evaporator inlet/outlet routed for left end access.		
INSULATION	Foamed-in-place polyurethane; 2" walls, 1 1/2" top and floor.		
OPTIONAL ACCESSORIES	<ul style="list-style-type: none"> • Optional Dispensing Heads • Leg Set • Door Locks • Keg Couplers • Caster Sets • Shelf Kit • Faucet Locks 		

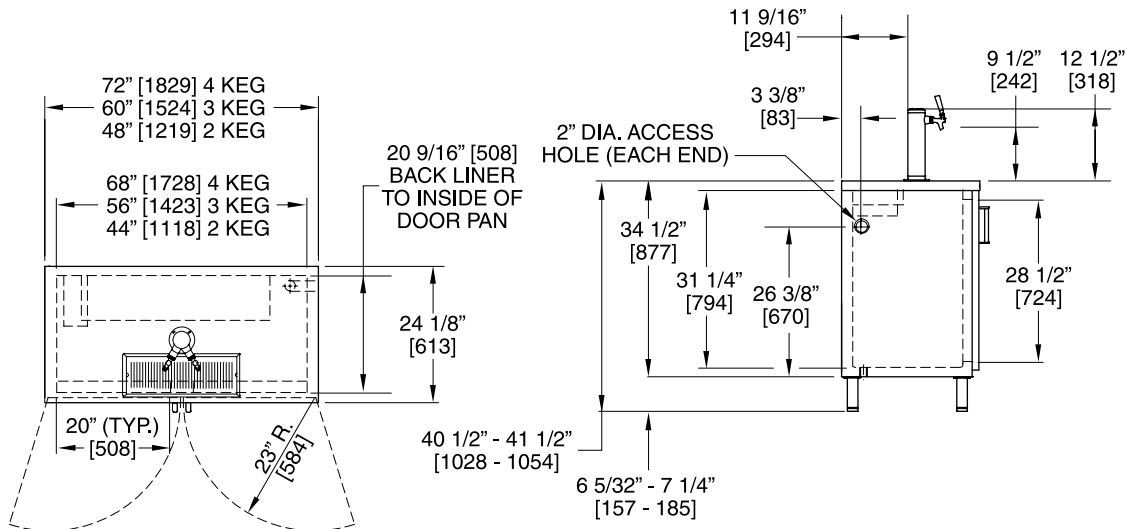

Perlick is committed to continuous improvement. Therefore, we reserve the right to change specifications without prior notice.

Preparing the Cabinet for Use – Direct Draw Dispensers - Remote

Parts List

- Faucet Standard.
- Faucet Head Assembly.
- Black Connector Hose $\frac{3}{16}$ " x 3'.
- $\frac{5}{16}$ " Air Hose.
- Spanner Wrench.
- Bag of Miscellaneous Parts.

Tools Required

- #2 Phillips Screwdriver.
- Spanner Wrench (included).
- #10 Crescent Wrench.
- $\frac{9}{16}$ " Allen Wrench.
- $\frac{3}{8}$ " Nut driver.
- Power Screwdriver (*if available*).

Uncrating and Inspection

Remove all crating material before operating. Carefully inspect cabinet for hidden damage. If damage is discovered, file your claim immediately with the transportation company. Perlick is not responsible for damage in transit.

Placing the Cabinet

Push the cabinet into place using rollers when necessary.

Leveling the Cabinet

When the cabinet is in place, check installation with a carpenter's level. A slight pitch to the drain side is desired. Water may accumulate if the cabinet is pitched to the opposite side.

Installing Casters or Legs (Optional)

Attach casters to the cabinet bottom in the holes provided. Use the supplied $\frac{1}{4}$ "- 20 x $\frac{3}{4}$ " hex head self-tapping machine screws. Use power driver if available.

Installing the Faucet and Dispensing Head

Before you begin: Wash tapping devices and faucet. Flush beer, tapping device and faucet lines with fresh water.

- Apply RTV around the base of the dispensing head to seal it to the top. Align the dispensing head over the holes on the cabinet top and use screws provided to secure standard to cabinet top. Wipe off excess RTV to complete the seal.

- Attach faucet to standard using spanner wrench to tighten coupling. Attach faucet handle to faucet.
- Insert flexible plastic air hose six to seven inches into bottom of faucet standard. Secure hose with tie wrap (supplied).

Plumbing

The floor drain in the right rear corner is equipped with a $\frac{3}{4}$ " female pipe thread connection with side or bottom access for beer drainer waste.

- Remove either side or bottom drain plug with an allen wrench and attach a $\frac{3}{4}$ " male pipe (provided by plumber) to an external drain connection.

The evaporator condensate drain line is located inside a cover below the evaporator and exits through an access hole in the left end of the cabinet. To run the drain line to the right end of the cabinet into the same drain line as the beer drainer, a tee is required, order part No. 57779.

A 2" access hole in the right end of the cabinet can be used as well for an evaporator condensate drain line exit.

CAUTION: Do not overtighten drain fitting as it may damage the threads.

NOTE: The end of the CO₂ line is coiled inside the cabinet. Connect this line to the pressure supply with a hose and fitting.

Electrical

The cabinet must be connected to a separately fused power source (see electrical specification plate) and grounded in accordance with National and Local Electrical Codes.

Caution: Do not attempt to operate the equipment on any other power source than that listed on the Electrical Specification plate.

IMPORTANT WARNING

To avoid compressor damage.

**DO NOT RUN UNIT
IF CABINET HAS BEEN
LAID ON ITS BACK**

If cabinet has been laid on its back for any reason, place it back into the upright position and allow it to stand for 24 hours before running unit.

Installation and Tapping – Direct Draw Dispensers - Remote

Connecting the Keg Coupler (when Supplied by Perlick)

- Place one brown leather washer into black beer line connector hose on hex nut side. Screw connector to stainless steel beverage line on faucet standard. Tighten with a wrench, but do not over tighten.
- Make sure lever handle on the keg coupler is in the **UP** (untapped) position. Place one brown leather washer into wing nut end of black beer line connector hose and thread onto top of keg coupler. Hand tighten.
- Place clamp on one end of red air line. Push end over air valve located inside cabinet. Tighten clamp with screwdriver. Turn shut-off valve to **OFF** (horizontal) position.
- Place clamp on the other end of red air line and push over tailpiece on coupler. Tighten clamp with screwdriver.

CAUTION: Do not use keg coupler as a handle to lift keg.

Tapping a Single Valve Keg (Sankey):

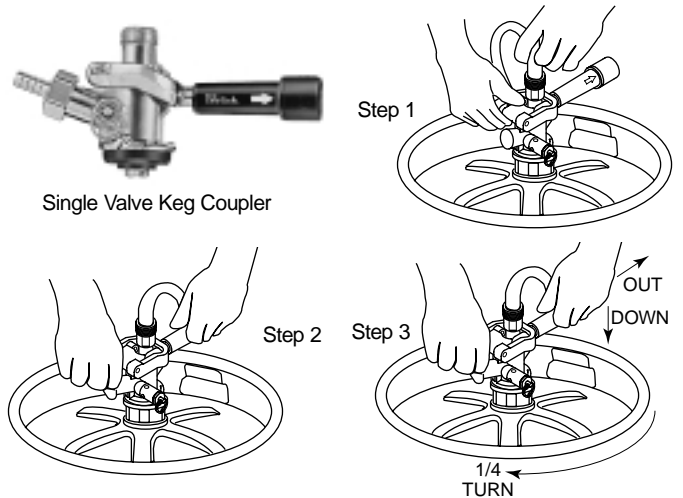

- Be sure beer faucet is in closed position.
- Align keg lugs with lug openings on bottom of coupler.
- Turn clockwise 1/4 turn. Pull handle out and down. Keg is now tapped.
- Open shut-off valve on air divider located inside of the cabinet.
Important: Be sure to close this valve when untapping keg.



Installation and Tapping – Direct Draw Dispensers - Remote

Connecting the Regulator to the CO₂ Cylinder

- Remove blue plug from regulator fitting. (Note: Do not remove the carbonic washer).
- Screw regulator onto gas cylinder valve. Tighten with wrench until vertically straight. Be sure that shut-off valve (**black lever**) on regulator is in the OFF (**horizontal**) position.
- Place a screw clamp over end of red air line and push onto regulator tailpiece. Tighten clamp with a screwdriver.

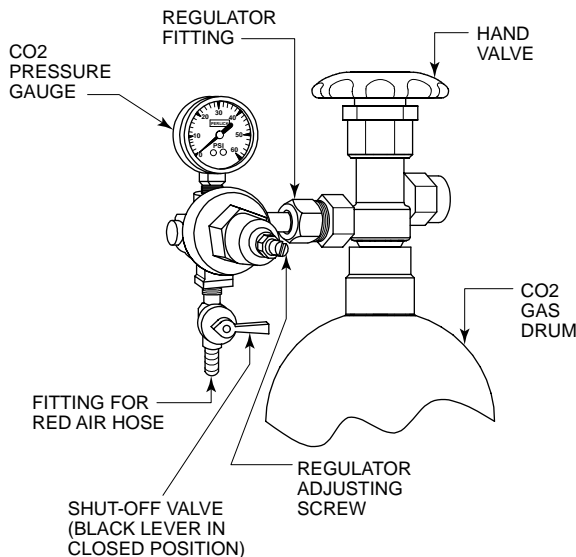

Adjusting the CO₂ Gas Flow

- Turn regulator adjusting screw counterclockwise until it turns freely.
- Turn hand valve counterclockwise on CO₂ cylinder to the fully open position.
- Turn regulator adjusting screw clockwise until desired pressure is reached (approximately 12-15 lbs.). Tighten stop nut on adjusting screw.
- Open shut-off valve on bottom of regulator.

CO₂ Leak Test

Dilute a small amount of liquid dishwashing soap and rub the soapy mixture around each connection. If bubbles appear, tighten connection.

Replacing CO₂ Gas Cylinder

- Turn CO₂ hand valve clockwise until seated and close shut-off valve on regulator.

- Unscrew regulator from cylinder fitting.
- Replace carbonic washer (Part No. 157F2P), if needed and reattach regulator to filled cylinder.
- Turn CO₂ hand valve counterclockwise until fully open. Turn regulator shut-off valve to open position.
- Adjust CO₂ gas flow as required, turning clockwise for higher pressure.

Proper CO₂ Handling

ALWAYS...

- Connect a regulator (reducing valve) to CO₂ cylinder.
- Secure cylinder in upright position whether in storage or in use.
- Keep cylinder away from heat. Rupture disc vents at 122° F. maximum.
- Ventilate room after high pressure gas leakage.
- Check the last DOT test date on cylinder neck before filling. If more than five years old, the cylinder must be retested to DOT specifications.
- Be sure CO₂ cylinder outlet fitting is free of dust or dirt before attaching regulator.
- Store CO₂ cylinder and regulator assembly upright.
- Allow only properly trained and experienced personnel to handle high pressure gas.

NEVER...

- Connect cylinder directly to a keg without a regulator (reducing valve).
- Drop or throw regulator or CO₂ cylinder.
- Transport CO₂ cylinder in a closed vehicle.
- Apply oil to a regulator.
- Shut off CO₂ cylinder when not in use. You will not save gas by doing so!
- Allow untrained, inexperienced personnel to handle high pressure gas.

Failure to heed this warning could result in personal injury or death.

WARNING/SAFETY INSTRUCTIONS

Beverage systems pressurized with carbon dioxide or nitrogen must be equipped with two safety relief valves; one at the cylinder regulator and the other in the gas line upstream on the product tanks.



Draft Beer Information – Direct Draw Dispensers - Remote

Temperature

One of the most common causes of dispensing problems is improper temperature. Draft beer should be stored at a temperature between 32° and 38°. At warmer temperatures, beer will foam.

At temperatures lower than 30° F., beer will freeze. When beer freezes, the alcohol in the beer may separate and cause the beer to be cloudy with an “off” taste.

HOW TEMPERATURE AFFECTS DRAFT BEER

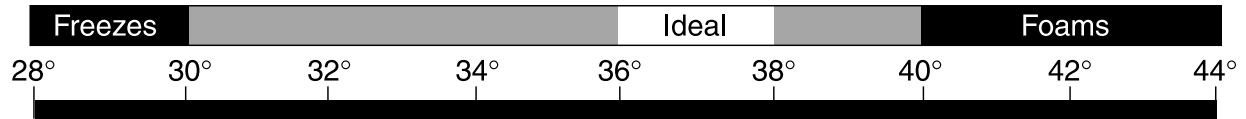

Perlick is committed to continuous improvement. Therefore, we reserve the right to change specifications without prior notice.

Cleaning the Beer System – Direct Draw Dispensers - Remote

The entire beer system, to include the faucet, flexible beer line and tapping devices must be cleaned at regular intervals. We recommend flushing the entire system with fresh water immediately after a keg has been emptied. Once each month the system should be cleaned chemically.

It is recommended that you purchase Perlick's Pump Type Sterilizer, as shown below. It is equipped with an adapter that attaches directly to the faucet shank in lieu of the faucet. It is also available with a slip coupling for those who choose to clean their faucets in place.

Part Nos.	Description
887P	½ Gallon sterilizer w/faucet coupling.
887PSC	½ Gallon sterilizer w/slip coupling.
848A33	33oz. Liquid alkaline cleaner.



No. 887P

Cleaning the draft beer system will help to eliminate the buildup of the following materials:

■ Bacteria:

Beer is an excellent food for bacteria (none of which is harmful). Proper conditions may begin the growth of bacteria in draft beer and on the beer faucet. By regular cleaning, we prevent this bacterial buildup and maintain the quality of the draft beer. Greenish or

yellowish colored material on the faucet may indicate bacterial growth.

■ Yeast:

All domestic draft beers contain a small amount of yeast which remains in the beer from the fermentation process. When the temperature of draft beer exceeds 50° a process of secondary fermentation may take place. The beer faucet may exhibit a white colored substance (yeast build up) if not cleaned on a regular basis.

■ Beer Stone:

All beer contains calcium which is present from the grains used in the brewing process. It is an important natural material in draft systems in that as it oxidizes it coats the internal parts of the beer lines and equipment. This thin coat of beer stone helps prevent the beer from picking up strong metallic or plastic flavors as it flows through the system. The beer stone will continue to build if the system is not cleaned properly or regularly and can cause drawing problems if it begins to flake off. Beer stone is present if one can see a brownish color on the faucet or inner wall of the beer line, or tobacco-like flakes in the beer.

Cleaning the Cabinet

Use a mild detergent and water to clean the inside and outside of the cabinet. Dry thoroughly. Never use a scouring pad or abrasive cleanser.

NOTE: An industrial strength, commercial cleaner can be used to clean the outside of painted cabinets.

Cleaning the Condenser

Use a long handled, stiff brush to clean the dirt from the front surface of the condenser. Keeping the condenser free from dust and dirt will ensure efficient operation.

CAUTION: Do not bend the fins while brushing the front of the condenser.

Pouring a Perfect Glass of Beer – Direct Draw Dispensers - Remote

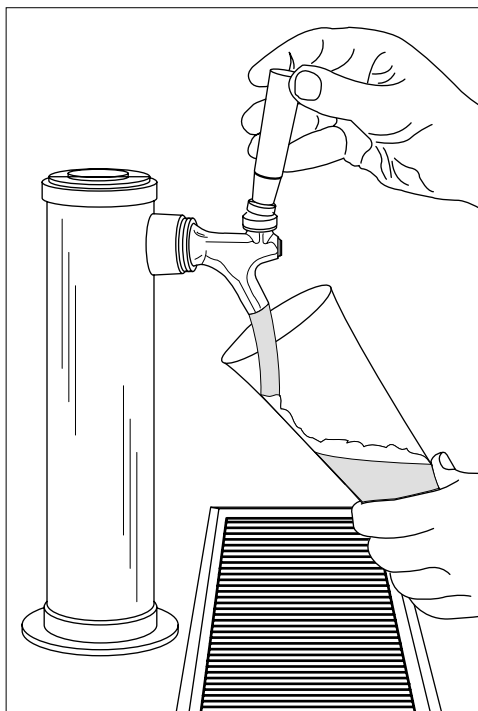

STEP 1

Start with a clean glass. Place the glass at a 45° angle, one inch below faucet. Do not let the glass touch the faucet. Open the faucet all the way.

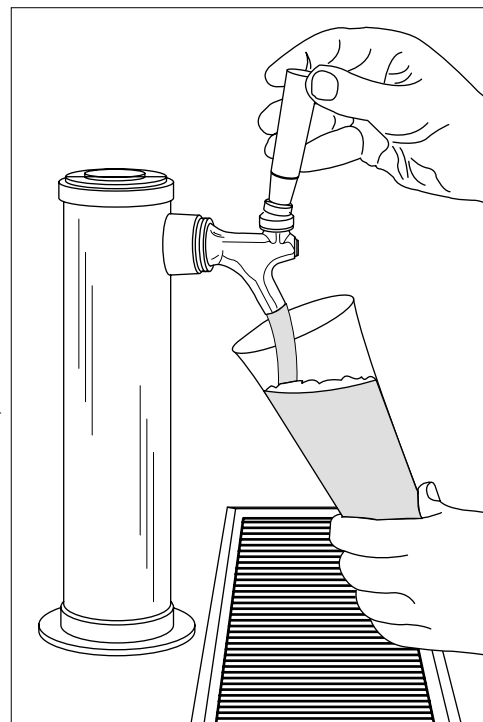

STEP 2

After the glass has reached half full, gradually bring the glass to the upright position

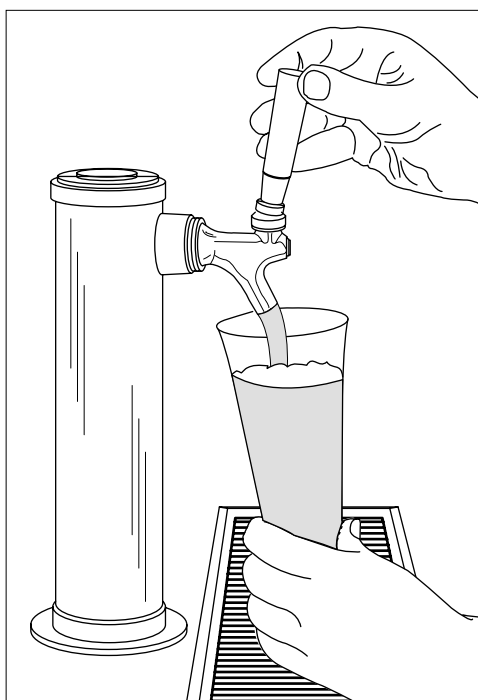

STEP 3

Let the remaining beer run straight down the middle of the glass. This ensures proper release of CO₂ by producing a ¾" to 1" foam head.



STEP 4

Close the faucet quickly and completely.

Trouble Shooting – Direct Draw Dispensers - Remote

Beer Service Problems

■ Wild Beer:

Dispensed beer has either too much foam or is all foam.

CAUSES:

- Beer has been dispensed improperly.

Solution: See pouring instructions on page 8.

- Regulator pressure is set too high.
- Warm keg temperature.

Solution: Keg must be colder than 40°. Target temperature is between 36° and 38° F.

- Cabinet door is opened and closed frequently and temperature is warmer than 38° F.

Solution: Adjust temperature to between 36° and 38° F.

- Kinks, dents or obstructions in the line.
- Using oddly shaped glasses. Frosted, waxed or styrofoam containers may cause foaming.
- Dispenser has been turned off for a long period of time.
- Faucet is bad, dirty or in a worn condition.
- Regulator malfunction.

■ Flat Beer:

Foamy head disappears quickly; beer lacks brewery fresh flavor.

CAUSES:

- Dirty glassware.
- CO₂ pressure is too low, due to leak or pressure setting.
- CO₂ is turned off at night.
- Cooler is too cold.
- CO₂ leak or defective (sticking) check valve.
- Sluggish CO₂ regulator.

■ Cloudy Beer:

Beer in glass appears hazy, not clear.

CAUSES:

- Dirty glass.
- Dirty faucet or beer line.
- Frozen or nearly frozen beer.
- Old beer.
- Beer that has not been refrigerated for a long period of time.

Beer and CO₂ Facts

Keg Size	No. of Gallons	No. of Oz.	No. of Cases	No. of 12Oz. Servings	Full Keg Weight
Quarter	7¾	992	3.445	105	87 lbs.
Half	15½	1,984	6.889	210	161 lbs.

- Beer foam is 25% liquid beer and 75% CO₂ gas. Don't waste it!
- Most people prefer beer stored at 38° F.
- Beer lines and faucets require regular cleaning (see cleaning instructions on page 7).
- A fully-charged 4.2 lb. CO₂ cylinder will dispense approximately 5½ to 6½ half barrels.
- CO₂ gas gives beer its sparkling effervescence. It also gives beer its creamy head of foam.

Replacement Parts – Direct Draw Dispensers - Remote

MODEL NOS.	DR2KP	DR3KP	DR4KP
All Models			
Left hinged door assembly	64357SLBL-LK	64357SLBL-LK	64357SLBL-LK
Left hinged door assembly, SS	64357SLSS-LK	64357SLSS-LK	64357SLSS-LK
Right hinged door assembly	64357SRBL-LK	64357SRBL-LK	64357SRBL-LK
Right hinged door assembly, SS	64357SRSS-LK	64357SRSS-LK	64357SRSS-LK
Magnetic door gasket	62085-1	62085-1	62085-1
Hinge set, left	63407L	63407L	63407L
Hinge set, right	63407R	63407R	63407R
Elbow-nylon 3/4" F.P.T. x 1/2" barb	57736-1	57736-1	57736-1
Glass rack	C24639-1	C24639-1	C24639-1
Wiring harness	61247-1	61247-1	61247-1
Fan motor	C15239A	C15239A	C15239A
5 1/2" diameter fan blade	57699	57699	57699
Fan guard assembly	C25395	C25395	C25395
Two keg model			
Two-way air distributor assembly	C18942	N/A	N/A
Complete coil assembly	62495A	N/A	N/A
1/2"trans vinyl beverage tubing 9 ft.	1390R	N/A	N/A
Three and four keg models			
Three-way air distributor assembly	N/A	C18943	N/A
Complete coil assembly	N/A	62496A	N/A
1/2"trans vinyl beverage tubing 10.5 ft.	N/A	1390TR	N/A
Four-way air distributor assembly	N/A	N/A	C18944
Complete coil assembly	N/A	N/A	62496A
1/2"trans vinyl beverage tubing 13 ft.	N/A	N/A	1390TR



Perlick is committed to continuous improvement. Therefore, we reserve the right to change specifications without prior notice.

Replacement Parts – Direct Draw Dispensers - Remote

For Single Valve Keg Coupler (Series D)

Item No.	Part No.	Description
1	26000D	Single valve keg coupler
2	C14316	"O" ring
3	31080-2P	Ball check
4	31089-2P	"O" ring (3 per assembly)
5	31088-2P	Bottom seal washer
6	31087-2P	Probe washer domestic
7	157R2P	Coupling Gasket
8	23682-2P	Check valve

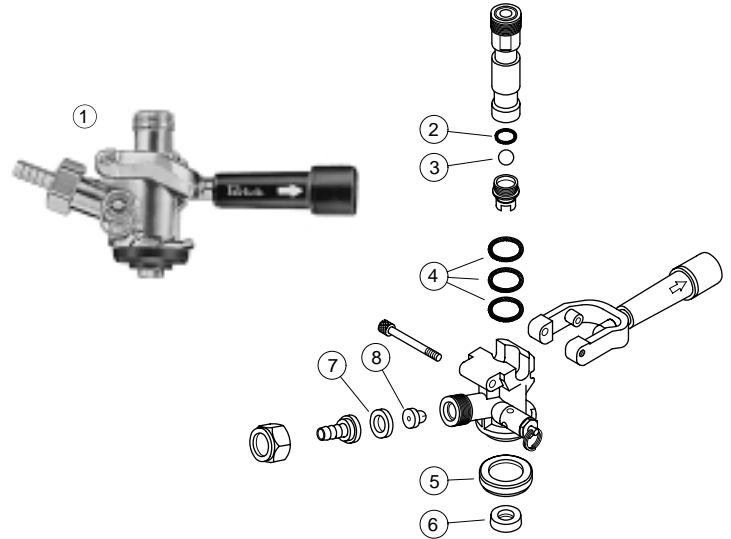

Miscellaneous

Part No.	Description
157L2P	Beer line connector gasket
57F2P	CO ₂ tank washer
1392R	Red air hose
529	Beer hose
2928D	Twin gauge CO ₂ regulator

Wiring Diagram – Direct Draw Dispensers - Remote

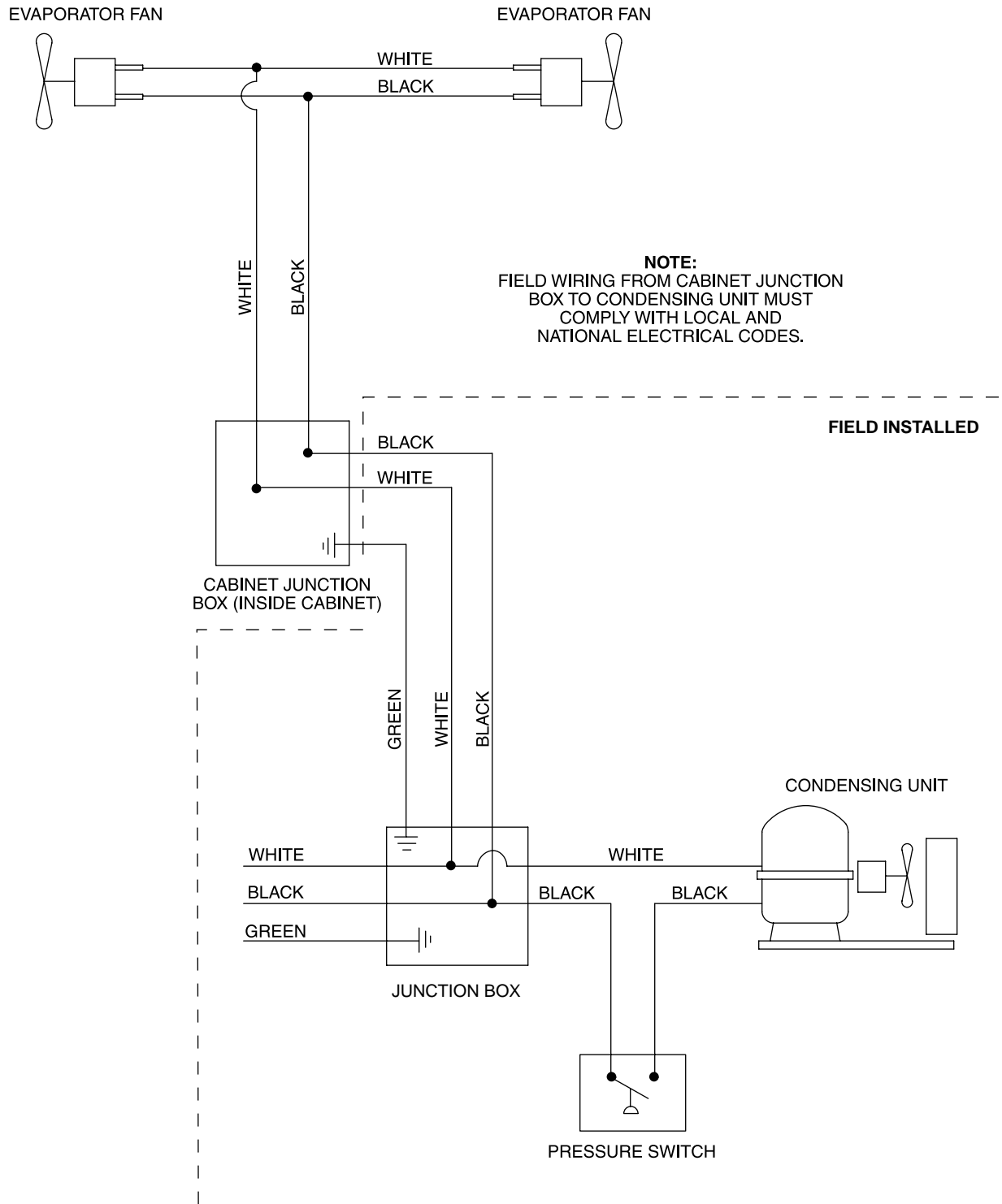

8300 West Good Hope Road • Milwaukee, WI 53223 • Phone 414-353-7060 • Fax 414-353-7069
Toll Free 800-558-5592 • E-Mail: Perlick@Perlick.com • www.Perlick.com

Perlick is committed to continuous improvement. Therefore, we reserve the right to change specifications without prior notice. Form No. Z2030A Rev. 12.05.03